

ignion[™]

Your innovation.
Accelerated.

Small-scale antenna for any IoT design

APPLICATION NOTE
ONE mXTEND[™] (NN02-201)

THE ONE mXTEND[™] TINY ANTENNA THAT FITS IN ALL BOARDS

- **Antenna Component:** ONE mXTEND[™] NN02-201
- **Dimensions :** 7.0 mm x 3.0 mm x 1.0 mm
- **Frequency regions:** 880-960 MHz, 1710-2170 MHz and 824-894 MHz, 1850-2170 MHz

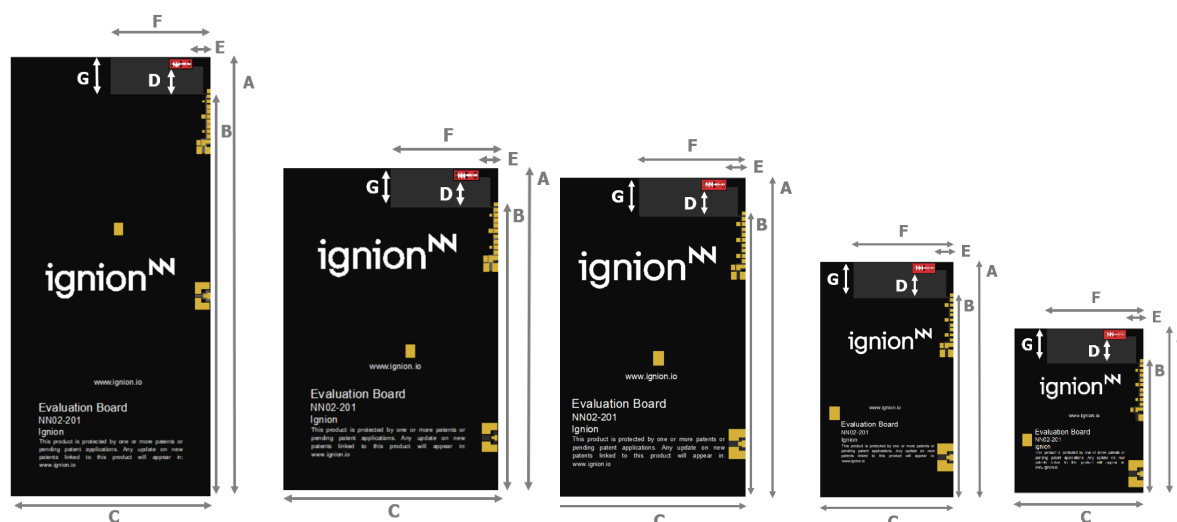

**Use only one component
regardless of the size and shape of your board**

A **unique component** can be used **for all the different board sizes**. Discover within this application note the performance of the ONE mXTEND[™] depending of different PCB boards.

Thanks to its miniature size, only 7.0 x 3.0 x 1.0 mm, this tiny antenna booster fits in about all the different platforms. With its tiny volume, **only 21mm³**, this **multiband** antenna enables **cellular IoT worldwide connectivity** in the smallest space ever.

Use this super slim booster at many different bands avoiding the usual problem with size restrictions. The same antenna can be used to cover selected frequency bands within the standards 2G, 3G, 4G and 5G all in one antenna package.

Cellular IoT made simple: ONE mXTEND[™].

TABLE OF CONTENTS

1. PRODUCT DESCRIPTION NN02-201	4
2. PERFORMANCE vs EVALUATION BOARD SIZE	5
2.1. EVALUATION BOARD	5
2.2. VSWR AND EFFICIENCY	6
2.2.1. 2G/3G EU BANDS	6
2.2.2. 2G/3G USA BANDS	7
2.3. MATCHING NETWORK	8
2.3.1. 2G/3G EU BANDS	9
2.3.2. 2G/3G USA BANDS	10

1. PRODUCT DESCRIPTION NN02-201

The IoT market is continuously growing and the set of IoT devices with many different requirements and form factors are endless. An antenna component capable of being easily adapted to all this configuration is presented herein. The ONE mXTEND[™] antenna booster has been specifically designed for providing multiband performance in wireless devices with small space requirements. It is a miniature antenna capable of being adapted, with a high level of flexibility, to the antenna designer needs. Featured by an extremely reduced package, the ONE mXTEND[™] is a versatile product capable of enabling 2G, 3G, 4G, and 5G coverage through the same single antenna package. This application note gathers the performance of the ONE mXTEND[™] antenna booster (NN02-201) when mounted onto various sized evaluation boards (EB). The configuration presented herein is tuned to provide operation in the 2G and 3G communication standards GSM850, GSM900, GSM1800/DCS, GSM1900/PCS and UMTS.

TOP

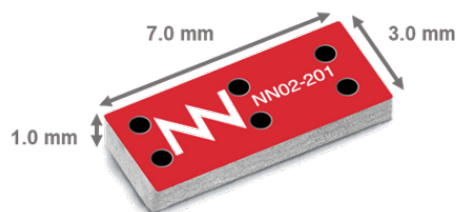

BOTTOM



Material: The ONE mXTEND[™] antenna booster is built on glass epoxy substrate.

APPLICATIONS

- Asset Tracking
- Fleet Management
- Modules
- IoT
- Routers
- Handsets and smartphones
- Tablets and PCs
- Digital cameras
- Sensors
- Smartwatches and wearables

BENEFITS

- High efficiency
- Small size
- Cost-effective
- Easy-to-use (pick and place)
- Off-the-Shelf standard product (no customization is required)

The ONE mXTEND[™] antenna booster belongs to a new generation of antenna solutions based on Virtual Antenna[™] technology owned by Ignion. This technology enables replacing conventional and custom antenna solutions by a new class of so-called antenna boosters, delivered in the form of a new range of miniature and off-the-shelf chip antenna components. These new chip antennas are by nature multiband and multipurpose, so they fit in a variety of wireless platforms to provide a wireless link at many different communication services. By using a Virtual Antenna[™] component the design becomes more predictable compared to a custom solution, making the whole process **faster, cheaper and easier**.

2. PERFORMANCE vs EVALUATION BOARD SIZE

2.1. EVALUATION BOARD

The performance of the ONE mXTEND[™] antenna booster is measured in different EBs featured by different sizes. This application note is intended to illustrate on one hand, how the antenna performance varies according to the ground plane length of any printed circuit board (PCB), and on the other hand, how our ONE mXTEND[™] antenna booster can be easily adapted to the different scenarios by simply adjusting the matching network components. The antenna part remains the same and the operating frequencies can be easily tuned through the matching network design. The following results cover a wide scope of EB sizes (length and width), ranging from 131mm x 60mm down to 51mm x 40mm ([Figure 1](#))



Measure	mm
A	131 – 51
B	120 – 40
C	60 – 54
D	8.0
E	5.0
F	30
G	11

Tolerance: ±0.2 mm

D: Distance between the ONE mXTEND[™] antenna booster and the ground plane.

Material: The evaluation board is built on FR4 substrate. Thickness is 1 mm.

Clearance Area: 30 mm x 11.0 mm (FxG)

Figure 1 – Evaluation boards with different form factors and different EB sizes.

Please note that the ONE mXTEND[™] is a versatile antenna solution able to cover other frequency ranges. If your IoT device is to operate in any other band, please contact to support@ignion.io for assistance.

2.2. VSWR AND EFFICIENCY

This section gathers the antenna performance in terms of VSWR (Voltage Standing Wave Ratio) and Total Efficiency results versus frequency (GHz) for the 2G, 3G communication standards used in Europe (EU) and USA.

2.2.1. 2G/3G EU BANDS

In this case, the matching network (Table 3) has been tuned to cover the European 2G and 3G communication standards in the frequency range of 880-960MHz and 1710-2170MHz.

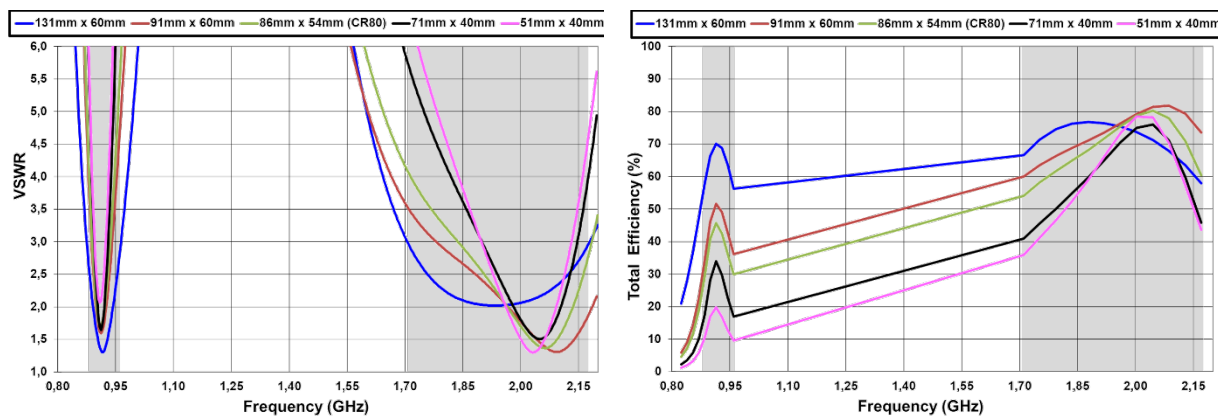

Figure 2 – VSWR and Total Efficiency for the 880 – 960 MHz frequency range and for the 1710 – 2170 MHz frequency range considering the different EB sizes. ([Figure 1](#))

A x C (mm)	LFR (880 – 960MHz)					HFR (1710 – 2170MHz)				
	η_a 880MHz	η_a 960MHz	Min	Max	Av. η_a	η_a 1710MHz	η_a 2170MHz	Min	Max	Av. η_a
131 x 60	54.9	56.3	54.9	70.1	63.8	66.5	57.9	57.9	76.7	71.0
91 x 60	30.9	36.1	30.9	51.3	43.3	60.0	73.6	60.0	81.8	72.9
86 x 54 (CR80)	26.4	29.9	26.4	45.6	37.4	54.1	60.4	54.1	80.2	68.5
71 x 40	15.4	17.0	15.4	33.6	24.5	41.0	45.9	41.0	75.9	59.6
51 x 40	9.1	9.7	9.1	19.6	14.2	36.0	43.6	36.0	78.5	58.5

Table 1 – Antenna efficiency comparison considering the different EB sizes ([Figure 1](#))

2.2.2. 2G/3G USA BANDS

In this case, the matching network has been tuned to cover the USA 2G and 3G communication standards in the frequency range of 824-894MHz and 1850-2170MHz.

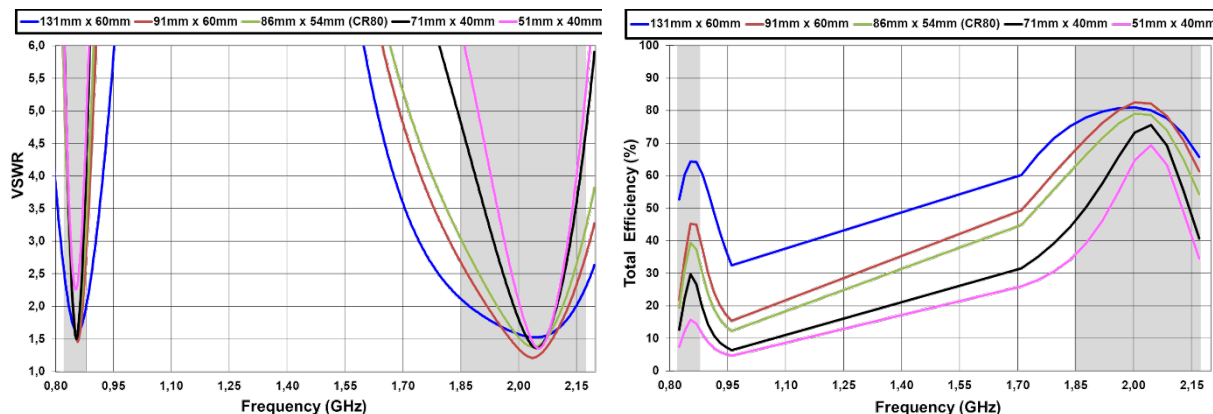

Figure 3 – VSWR and Total Efficiency for the 824 – 894 MHz frequency range and for the 1850 – 2170 MHz frequency range considering the different EB sizes ([Figure 1](#))

A x C (mm)	LFR (824 – 894MHz)					HFR (1850 – 2170MHz)				
	η_a 824MHz	η_a 894MHz	Min	Max	Av. η_a	η_a 1850MHz	η_a 2170MHz	Min	Max	Av. η_a
131 x 60	52.7	57.1	52.7	64.3	59.5	60.1	65.8	60.1	80.8	76.9
91 x 60	21.8	32.8	21.8	45.1	35.7	68.0	61.3	61.3	82.4	75.4
86 x 54 (CR80)	19.3	26.0	19.3	39.3	30.1	62.9	54.2	62.9	78.7	69.8
71 x 40	12.7	16.2	12.7	29.5	21.2	46.2	40.7	40.7	75.5	60.5
51 x 40	7.4	9.8	7.4	15.4	11.9	35.9	34.5	34.5	69.2	52.2

Table 2 – Antenna efficiency comparison considering the different EB sizes.

2.3. MATCHING NETWORK

ONE mXTEND[™] antenna booster needs a matching network to connect to your 2G and 3G receiver. As seen, the antenna performance depends on the ground plane size. This section describes the recommended matching network topology (Figure 4) and the resulting matching network configuration when measured in the different sized EBs (**Figure 1**). Please note that different devices with different form factors, ground planes and nearby components may need a different matching network.

If you need assistance to design your matching network beyond this application note, please contact support@ignion.io, or try our free-of-charge¹ [Antenna Intelligence Cloud](#) design service, which will get you a chip antenna design including a custom matching network for your device in 24h¹. Other information related to Ignion's range of R&D services is available at: <https://www.ignion.io/rdservices/>

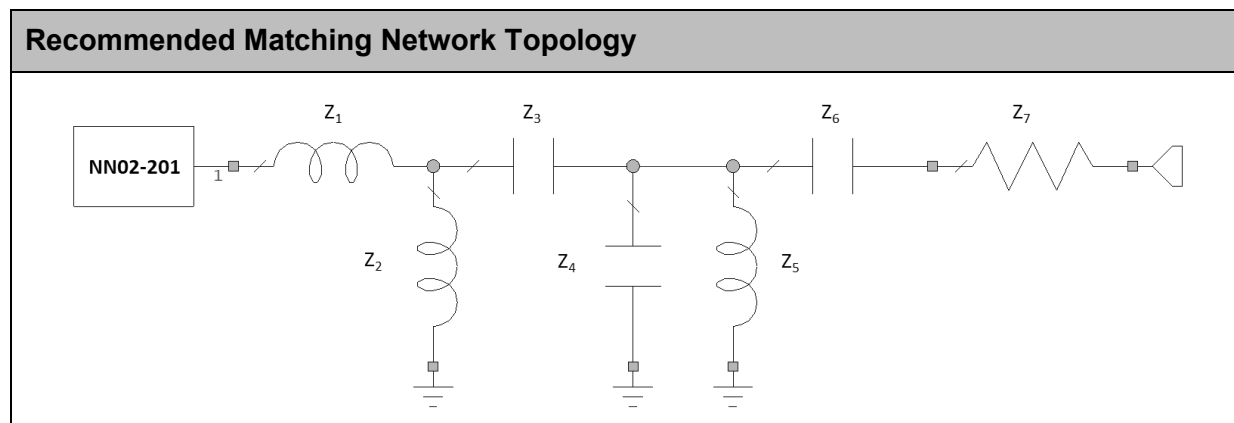

Figure 4 – Topology of matching network mounted at the different solutions.

The matching network topology (Figure 4) remains equal for all the analyzed EBs of different sizes (**Figure 1**) and just the values of the matching network components must be adjusted to tune the antenna performance to the required operating frequency bands (sections 2.3.1 and 2.3.2). To ensure optimal results, the use of high-quality factor (Q) and tight tolerance components is highly recommended (e.g. Murata components).

Please note that the antenna performance is always conditioned by its operating environment so that different devices with different printed circuit board sizes, components nearby the antenna, LCD's, batteries, covers, connectors, etc. affect the antenna performance. Accordingly, it is highly recommended placing pads compatible with 0402 and 0603 SMD components for a matching network as close as possible to the feeding point of the antenna element in the ground plane area, not in the clearance area. By tuning the matching network in your final design with your final surrounding components (batteries, displays, covers, etc.) you will be able to optimize the antenna performance without changing the antenna part.

¹ See terms and conditions for a free Antenna Intelligence Cloud service in 24h at: <https://www.ignion.io/antenna-intelligence/>

2.3.1. 2G/3G EU BANDS

This section gathers the recommended values for operating the 2G and 3G European communication standards ranging from 880 – 960 MHz and 1710 – 2170 MHz (Table 3 and Table 4).

A x C (mm)	Z ₁	Z ₂	Z ₃	Z ₄	Z ₅	Z ₆	Z ₇
131 x 60	10 nH	17 nH	1.1 pF	1.2 pF	16 nH	1.5 pF	3.0 nH
91 x 60	10 nH	17 nH	1.1 pF	1.1 pF	21 nH	1.2 pF	4.3 nH
86 x 54 (CR80)	10 nH	17 nH	1.1 pF	1.2 pF	21 nH	1.2 pF	4.3 nH
71 x 40	10 nH	17 nH	1.1 pF	1.3 pF	25 nH	1.1 pF	4.3 nH
51 x 40	10 nH	17 nH	1.1 pF	1.3 pF	30 nH	1.2 pF	4.3 nH

Table 3 – Values of the matching network components for the different EB sizes ranging from 131mm x 60mm down to 51mm x 40mm ([Figure 1](#))

Value	Part Number	
Z1	10 nH	LQW18AN10NG10
Z2	17 nH	LQW15AN17NG80
Z3	1.1 pF	GJM1555C1H1R1WB01
Z4	1.2 pF	GJM1555C1H1R2WB01
	1.1 pF	GJM1555C1H1R1WB01
	1.3 pF	GJM1555C1H1R3WB01
Z5	16 nH	LQW18AN16NG80
	21 nH	LQW18AN21NG80
	25 nH	LQW18AN25NG80
	30 nH	LQW18AN30NG80
Z6	1.5 pF	GJM1555C1H1R5WB01
	1.2 pF	GJM1555C1H1R2WB01
	1.1 pF	GJM1555C1H1R1WB01
Z7	3.0 nH	LQW15AN3N0G80
	4.3 nH	LQW18AN4N3G80

Table 4 – Values and part numbers of the components used for the matching networks for the different EB sizes ranging from 131mm x 60mm down to 51mm x 40mm ([Figure 1](#))

2.3.2. 2G/3G USA BANDS

This section gathers the recommended values for operating the 2G and 3G USA communication standards ranging from 824 –894 MHz and 1850 – 2170 MHz (**Table 5** and **Table 6**)

A x C (mm)	Z ₁	Z ₂	Z ₃	Z ₄	Z ₅	Z ₆	Z ₇
131 x 60	11 nH	21 nH	0.7 pF	11 nH	1.2 pF	2.0 pF	2.7 nH
91 x 60	11 nH	21 nH	0.7 pF	18 nH	1.2 pF	1.7 pF	3.5 nH
86 x 54 (CR80)	11 nH	21 nH	0.7 pF	20 nH	1.2 pF	1.9 pF	3.0 nH
71 x 40	12 nH	21 nH	0.7 pF	27 nH	1.3 pF	2.0 pF	3.3 nH
51 x 40	13 nH	21 nH	0.7 pF	27 nH	1.1 pF	2.2 pF	5.0 nH

Table 5 – Values of the matching network components for the different EB sizes ranging from 131mm x 60mm down to 51mm x 40mm ([Figure 1](#))

Value	Part Number	
Z1	11 nH	LQW18AN11NG80
	12 nH	LQW18AN12NG10
	13 nH	LQW18AN13NG80
Z2	21 nH	LQW15AN21NG80
Z3	0.7 pF	GJM1555C1HR70WB01
	11 nH	LQW18AN11NG80
	18 nH	LQW18AN18NG10
	20 nH	LQW18AN20NG00
Z4	27 nH	LQW15AN27NG10
	1.2 pF	GJM1555C1H1R2WB01
	1.3 pF	GJM1555C1H1R3WB01
	1.1 pF	GJM1555C1H1R1WB01
Z5	2.0 pF	GJM1555C1H2R0WB01
	1.7 pF	GJM1555C1H1R7WB01
	1.9 pF	GJM1555C1H1R9WB01
	2.2 pF	GJM1555C1H2R2WB01
Z6	2.7 nH	LQW15AN2N7G80
	3.5 nH	LQW15AN3N5G80
	3.0 nH	LQW15AN3N0G80
	3.8 nH	LQW15AN3N8G80
	3.3 nH	LQW15AN3N3G80
	5.0 nH	LQW15AN5N0G80

Table 6 –Values and part numbers of the components used for the matching networks for the different EB sizes ranging from 131mm x 60mm down to 51mm x 40mm ([Figure 1](#))

Do you need more help with your antenna for your device?

Use our **Antenna Intelligence Cloud service** and get your ready-to-test antenna design specially thought for your platform **free of charge**¹ and in **24 hours**.

<https://www.ignion.io/antenna-intelligence/>

Ignion products are protected by [Ignion patents](#).

All information contained within this document is property of Ignion and is subject to change without prior notice. Information is provided “as is” and without warranties. It is prohibited to copy or reproduce this information without prior approval.

Ignion is an ISO 9001:2015 certified company. All our antennas are lead-free and RoHS compliant.

ISO 9001: 2015 Certified



ignion[™]

Your innovation.
Accelerated.

Contact:
support@ignion.io
+34 935 660 710

Barcelona

Av. Alcalde Barnils, 64-68 Modul C, 3a pl.
Sant Cugat del Vallés
08174 Barcelona
Spain

Shanghai

Shanghai Bund Centre
18/F Bund Centre, 222 Yan'an Road East,
Huangpu District
Shanghai, 200002
China

New Delhi

New Delhi, Red Fort Capital Parsvnath Towers
Bhai Veer Singh Marg, Gole Market,
New Delhi, 110001
India

Tampa

8875 Hidden River Parkway
Suite 300
Tampa, FL 33637
USA