

ignion[™]

Your innovation.
Accelerated.

ALL mXTEND[™]: IMPACT OF CLEARANCE SIZE AND PCB SIZE ON EFFICIENCY

APPLICATION NOTE
ALL mXTEND[™] (NN02-220)

TABLE OF CONTENTS

1. PRODUCT DESCRIPTION NN02-220	3
2. CLEARANCE LENGTH EXPERIMENTS	4
2.1. EVALUATION BOARD	4
2.2. VSWR AND EFFICIENCY	5
2.3. MATCHING NETWORK	5
3. GROUND PLANE LENGTH EXPERIMENTS	7
3.1. EVALUATION BOARD	7
3.2. VSWR AND EFFICIENCY	8
3.3. MATCHING NETWORK	8

1. PRODUCT DESCRIPTION NN02-220

The ALL mXTEND[™] chip antenna component (NN02-220) has been specifically designed for providing multiband performance in wireless devices (in particular in mobile devices), enabling worldwide coverage by allowing operation in the communication standards GSM850, GSM900, GSM1800/DCS, GSM1900/PCS, UMTS, LTE700, LTE800, LTE850, LTE900, LTE1700, LTE1800, LTE1900, LTE2000, LTE2100, LTE2300, LTE2500, and LTE2600.

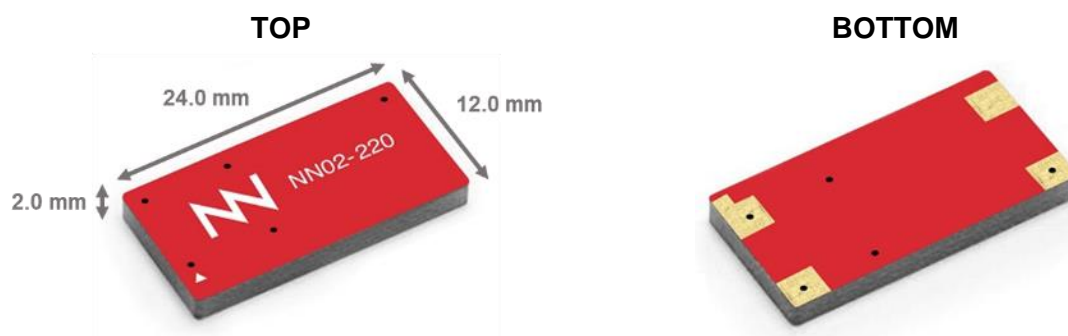

Material: The ALL mXTEND[™] chip antenna component is built on glass epoxy substrate.

APPLICATIONS

- Handsets
- Smartphones
- Tablets
- Laptop PCs
- Netbooks
- Modules
- Routers
- Smart meters
- Tracking devices

BENEFITS

- High efficiency
- Small size
- Cost-effective
- Easy-to-use (pick and place)
- Multiband behaviour (worldwide standards)
- Off-the-Shelf Standard Product (no customization is required)

The ALL mXTEND[™] chip antenna component belongs to a new generation of antenna solutions based on the Virtual Antenna[™] technology owned by Ignion. The technology is mainly focused on replacing conventional antenna solutions by miniature and standard components.

This project has received funding from the European Union's Horizon 2020 research and innovation programme under grant agreement N° 674491



2. CLEARANCE LENGTH EXPERIMENTS

2.1 EVALUATION BOARD

This Evaluation Board EB_NN02-220-1B-2R-1P integrates an UFL cable to connect the ALL mXTEND™ chip antenna component with a SMA connector. The experiment consists of reducing the clearance length, going from 45mm (original case) to 25mm.



Clearance Length: 45 mm x 12mm



Clearance Length: 30 mm x 12mm



Clearance Length: 27 mm x 12mm



Clearance Length: 25 mm x 12mm

Measure	mm
A	142
B	60
C	45 – 25
D	12

Tolerance: ±0.2 mm

D: Distance between the edge of the PCB and the ground plane.

Clearance Area: C x D. D is fixed meanwhile C varies.

Material: The evaluation board is built on FR4 substrate. Thickness is 1 mm.

Figure 1 – Evaluation boards with different clearance lengths operating at ranges 698 – 960MHz and 1710 – 2690MHz.

2.2 VSWR AND EFFICIENCY

VSWR (Voltage Standing Wave Ratio) and Total Efficiency versus Frequency (GHz).

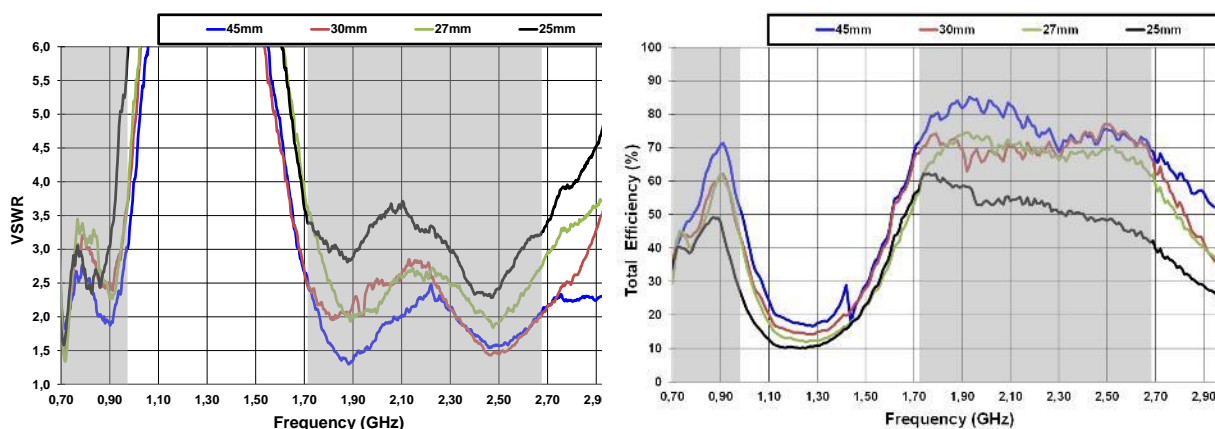

Figure 2 – VSWR and Total Efficiency for the 698 – 960 MHz frequency range and for the 1710 – 2690 MHz frequency range from the evaluation board (Figure 1).

C	LFR (698 – 960MHz)					HFR (1710 – 2690MHz)				
	η_a 698MHz	η_a 960MHz	Min	Max	Av. η_a	η_a 1710MHz	η_a 2690MHz	Min	Max	Av. η_a
45mm	40.7	60.7	40.7	71.0	60.7	72.5	77.2	76.4	71.6	90.3
30mm	35.4	46.8	35.4	62.2	50.6	68.2	65.0	61.1	77.5	70.6
27mm	29.4	48.0	29.4	62.3	49.1	55.7	62.0	55.7	74.7	68.6
25mm	34.5	30.0	30.0	49.7	41.8	56.1	42.0	40.9	62.7	52.5

Table 1 – Antenna efficiency (%) comparison considering the different clearance lengths.

2.3 MATCHING NETWORK

The specs of a Ignion standard product are measured in their evaluation board, which is an ideal case. In a real design, components nearby the antenna, LCD's, batteries, covers, connectors, etc. affect the antenna performance. This is the reason why it is highly recommended placing pads compatible with 0402 and 0603 SMD components for a matching network as close as possible to the feeding point. Do it in the ground plane area, not in the clearance area. This provides a degree of freedom to tune the ALL mXTEND[™] chip antenna component once the design is finished and taking into account all elements of the system (batteries, displays, covers, etc.).

Please notice that different devices with different ground planes and different components nearby the ALL mXTEND[™] chip antenna component may need a different matching network. To ensure optimal results, the use of high Q and tight tolerance components is highly recommended (Murata components). If you need assistance to design your matching network beyond this application note, please contact support@ignion.io, or try our free-of-charge¹ **NN Wireless Fast-Track** design service, you will get your chip antenna design including a custom

matching network for your device in 24h¹. Other related to NN's range of R&D services is available at: <https://www.ignion.io/rdservices/>

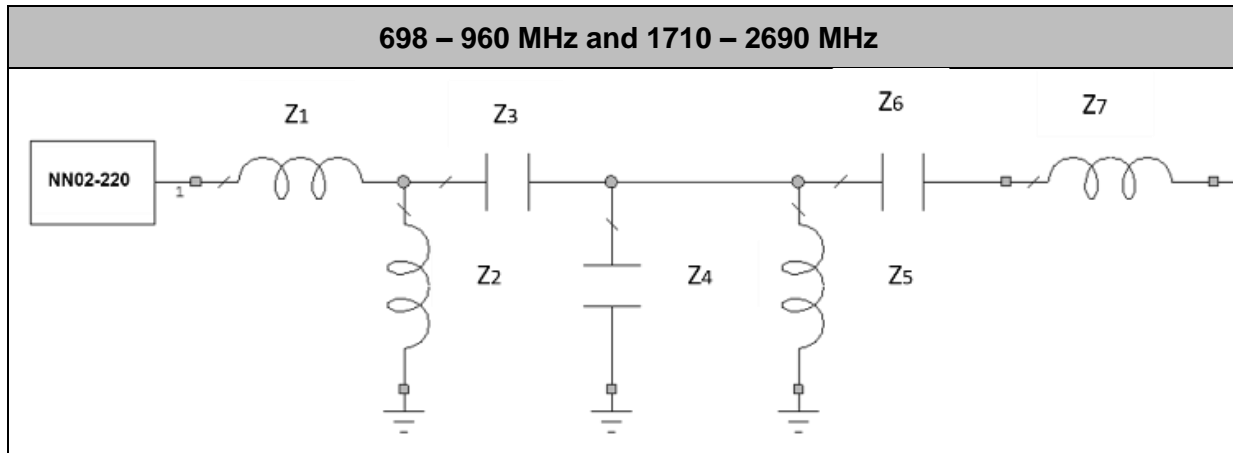

Figure 3 – Topology of matching network mounted for the different solutions.

C	Z ₁	Z ₂	Z ₃	Z ₄	Z ₅	Z ₆	Z ₇
45mm	4.7 nH	12 nH	1.2 pF	1.1 pF	9.1 nH	2.0 pF	2.2 nH
30mm	4.7 nH	12 nH	1.2 pF	1.1 pF	9.1 nH	1.8 pF	2.4 nH
27mm	4.7 nH	12 nH	1.2 pF	1.1 pF	9.1 nH	1.8 pF	2.2 nH
25mm	4.7 nH	12 nH	1.2 pF	1.1 pF	9.1 nH	2.0 pF	2.2 nH

Table 2 – Values of the components for each clearance length.

Component	Value	Part Number
Z ₁	4.7 nH	LQW15AN4N7B80
Z ₂	12 nH	LQW15AN12NG00
Z ₃	1.2 pF	GJM1555C1H1R2WB01
Z ₄	1.1 pF	GJM1555C1H1R1WB01
Z ₅	9.1 nH	LQW15AN9N1G00
Z ₆	2.0 pF	GJM1555C1H2R0WB01
	1.8 pF	GJM1555C1H1R8WB01
Z ₇	2.2 nH	LQW15AN2N2B80
	2.4 nH	LQW15AN2N4B80

Table 3 – Values and part numbers of the components used for the matching networks for the cases with clearance length equal to 45 mm, 30 mm, 27 mm and 25 mm.

¹ See terms and conditions for a free NN Wireless Fast-Track service in 24h at: <https://www.ignion.io/fast-track-project/>

3. GROUND PLANE LENGTH EXPERIMENTS

3.1 EVALUATION BOARD

This Evaluation Board EB_NN02-220-1B-2R-1P integrates an UFL cable to connect the ALL mXTEND[™] chip antenna component with a SMA connector. The experiment consists of reducing the ground plane length, going from 130mm (original case) to 40mm.

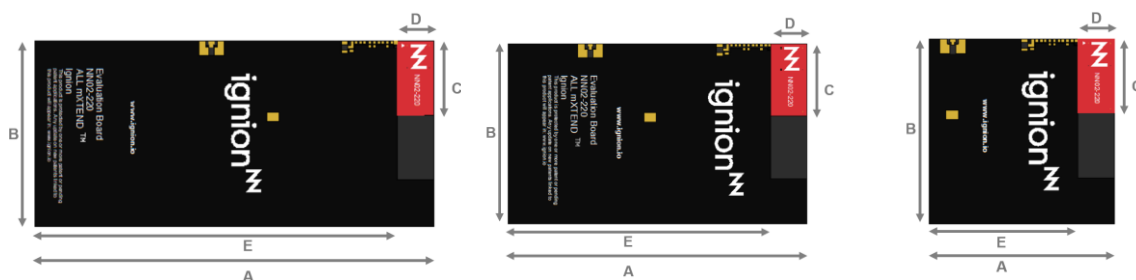

Ground plane Length: 130 mm

Ground plane Length: 100 mm

Ground plane Length: 60mm

Measure	mm
A	142-52
B	60
C	45
D	12
E	130-40

Tolerance: ±0.2 mm

D: Distance between the edge of the PCB and the ground plane.

Clearance Area: 45mm x 12mm (C x D).

Material: The evaluation board is built on FR4 substrate. Thickness is 1 mm.

Figure 4 – Evaluation boards with different ground plane lengths operating at ranges 698 – 960MHz and 1710 – 2690MHz.

3.2 VSWR AND EFFICIENCY

VSWR (Voltage Standing Wave Ratio) and Total Efficiency versus Frequency (GHz).

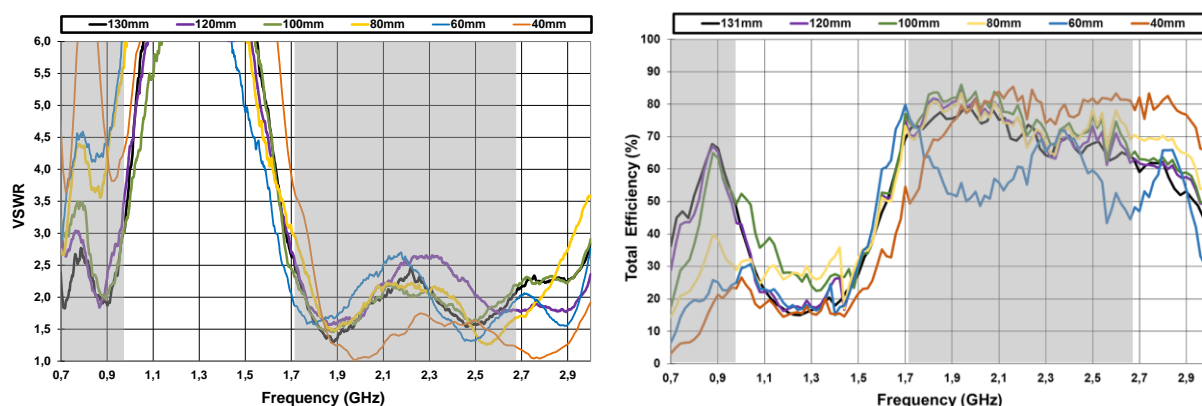

Figure 5 – VSWR and Total Efficiency for the 698 – 960 MHz frequency range and for the 1710 – 2690 MHz frequency range from the evaluation board (Figure 4).

E	LFR (698 – 960MHz)					HFR (1710 – 2690MHz)				
	η_a 698MHz	η_a 960MHz	Min	Max	Av. η_a	η_a 1710MHz	η_a 2690MHz	Min	Max	Av. η_a
130mm	40.7	60.7	40.7	71.0	60.7	72.5	77.2	76.4	71.6	90.3
120mm	22.8	55.9	22.4	67.1	50.8	73.0	72.1	63.4	86.2	74.2
100mm	17.8	53.0	17.8	64.9	44.7	75.5	64.2	63.0	86.0	75.5
80mm	14.8	30.7	14.8	39.9	28.3	71.6	70.0	64.6	83.3	74.1
60mm	12.8	20.9	12.8	24.1	19.7	72.3	58.2	57.1	75.1	65.7
40mm	3.9	23.4	3.9	23.4	13.3	52.7	81.1	49.6	85.0	70.6

Table 4 – Antenna efficiency (%) comparison considering the different ground plane lengths.

3.3 MATCHING NETWORK

The specs of a Ignion standard product are measured in their evaluation board, which is an ideal case. In a real design, components nearby the antenna, LCD's, batteries, covers, connectors, etc. affect the antenna performance. This is the reason why it is highly recommended placing pads compatible with 0402 and 0603 SMD components for a matching network as close as possible to the feeding point. Do it in the ground plane area, not in the clearance area. This provides a degree of freedom to tune the ALL mXTEND™ chip antenna component once the design is finished and taking into account all elements of the system (batteries, displays, covers, etc.).

Please notice that different devices with different ground planes and different components nearby the ALL mXTEND™ chip antenna component may need a different matching network. To ensure optimal results, the use of high Q and tight tolerance components is highly recommended (Murata components). If you need assistance to design your matching network beyond this application note, please contact support@ignion.io, or try our free-of-charge² **NN Wireless Fast-Track** design service, you will get your chip antenna design including a custom

matching network for your device in 24h². Other related to NN's range of R&D services is available at: <https://www.ignion.io/rdservices/>

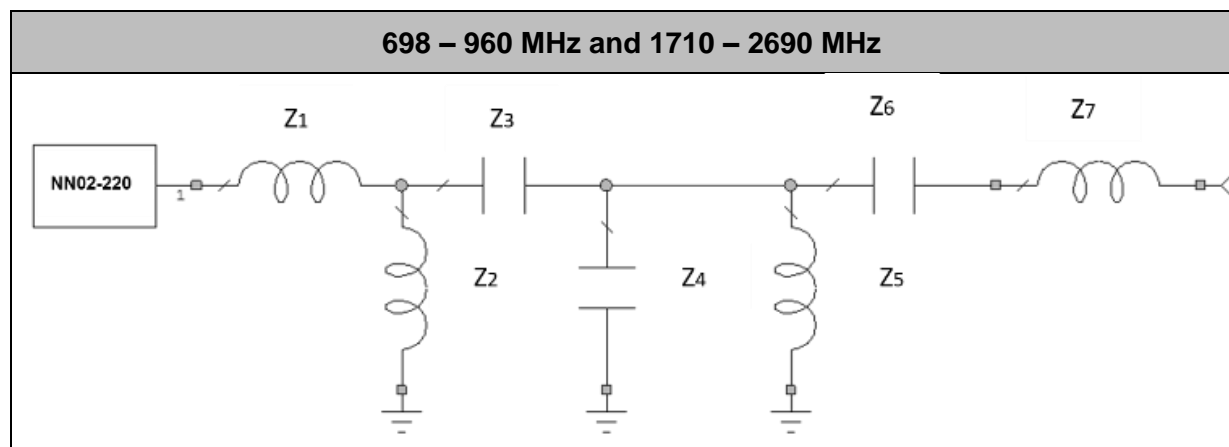

Figure 6 – Topology of matching network mounted for the different solutions.

E	Z ₁	Z ₂	Z ₃	Z ₄	Z ₅	Z ₆	Z ₇
130mm	4.7 nH	12 nH	1.2 pF	1.1 pF	9.1 nH	2.0 pF	2.2 nH
120mm	4.7 nH	12 nH	1.2 pF	1.1 pF	9.1 nH	2.2 pF	2.2 nH
100mm	4.7 nH	12 nH	1.2 pF	1.1 pF	9.1 nH	2.2 pF	2.2 nH
80mm	4.7 nH	13 nH	1.2 pF	1.1 pF	9.1 nH	2.2 pF	2.2 nH
60mm	4.7 nH	13 nH	1.2 pF	1.1 pF	9.1 nH	2.5 pF	2.2 nH
40mm	0 Ω	12 nH	1.2 pF	0.5 pF	9.1 nH	2.2 pF	2.2 nH

Table 5 – Values of the components for each clearance length.

Component	Value	Part Number
Z ₁	4.7 nH	LQW15AN4N7B80
Z ₂	12 nH	LQW15AN12NG00
	13 nH	LQW15AN13NG00
Z ₃	1.2 pF	GJM1555C1H1R2WB01
Z ₄	0.5 pF	GJM1555C1HR50WB01
	1.1 pF	GJM1555C1H1R1WB01
Z ₅	9.1 nH	LQW15AN9N1G00
Z ₆	2.0 pF	GJM1555C1H2R0WB01
	2.2 pF	GJM1555C1H2R2WB01
	2.5 pF	GJM1555C1H2R5WB01
Z ₇	2.2 nH	LQW15AN2N2B80

Table 6 – Values and part numbers of the components used for the matching networks for the cases with ground plane length equal to 130 mm, 120 mm, 100 mm, 80 mm, 60 mm, and 40 mm.

² See terms and conditions for a free NN Wireless Fast-Track service in 24h at: <https://www.ignion.io/fast-track-project/>

ignion[™]

Your innovation.
Accelerated.

Contact:
support@ignion.io
+34 935 660 710

Barcelona

Av. Alcalde Barnils, 64-68 Modul C, 3a pl.
Sant Cugat del Vallés
08174 Barcelona
Spain

Shanghai

Shanghai Bund Centre
18/F Bund Centre, 222 Yan'an Road East,
Huangpu District
Shanghai, 200002
China

New Dehli

New Delhi, Red Fort Capital Parsvnath Towers
Bhai Veer Singh Marg, Gole Market,
New Delhi, 110001
India

Tampa

8875 Hidden River Parkway
Suite 300
Tampa, FL 33637
USA