

ignion<sup>™</sup>

Your innovation.  
Accelerated.

# NAVIGATE GLOBALLY WITH RUN mXTEND<sup>™</sup>

APPLICATION NOTE  
RUN mXTEND<sup>™</sup> (NN02-224)

## Navigate globally with RUN mXTEND<sup>™</sup>

- **Antenna Component:** RUN mXTEND<sup>™</sup> NN02-224
- **Dimensions:** 12.0 mm x 3.0 mm x 2.4 mm
- **Frequency regions:** 1561 MHz, 1575 MHz, and 1598 MHz to 1606 MHz



With more than **80% of efficiency**, the new **RUN mXTEND<sup>™</sup>** chip antenna component covers the frequency ranges used for operating at the global navigation systems: **GPS**, **GLONASS** and **BeiDou**.

This new reference design illustrates a full satellite navigation performance, tested in two different evaluation board sizes, that allows location signal usability anywhere in the world.

The **miniature size** (12.0mm x 3.0mm x 2.4 mm) and the **high level of flexibility** of the standard component makes this solution one of the best options for any application to be developed where global navigation systems are involved. The RUN mXTEND<sup>™</sup> provides operation in three frequency regions: **1561 MHz** (BeiDou E1 band), **1575 MHz** (GPS L1 band) and from **1598 MHz to 1606 MHz** (GLONASS L1 band).

The RUN mXTEND<sup>™</sup> chip antenna component and other Ignion products based on its proprietary Virtual Antenna<sup>™</sup> technology are protected by one or more of the following [Ignion patents](#).

All information contained within this document is property of Ignion and is subject to change without prior notice. Information is provided “as is” and without warranties. It is prohibited to copy or reproduce this information without prior approval.

Ignion is an ISO 9001:2015 certified company. All our antennas are lead-free and RoHS and REACH compliant.

This project has received funding from the European Union’s Horizon 2020 research and innovation programme under grant agreement N° 674491



## TABLE OF CONTENTS

<b>1. PRODUCT DESCRIPTION NN02-224</b>	<b>4</b>
<b>2. EVALUATION BOARD GPS/GLONASS/BeiDou</b>	<b>5</b>
<b>2.1. QUICK REFERENCE GUIDE</b>	<b>5</b>
<b>2.2. EVALUATION BOARD</b>	<b>5</b>
<b>2.3. MATCHING NETWORK</b>	<b>6</b>
<b>2.4. VSWR AND TOTAL EFFICIENCY</b>	<b>7</b>
<b>2.5. RADIATION PATTERNS (1561, 1575 and 1598-1606 MHz), GAIN AND EFFICIENCY</b>	<b>8</b>
<b>3. EVALUATION BOARD CR80 GPS/GLONASS/BeiDou</b>	<b>9</b>
<b>3.1. QUICK REFERENCE GUIDE</b>	<b>9</b>
<b>3.2. EVALUATION BOARD</b>	<b>9</b>
<b>3.3. MATCHING NETWORK</b>	<b>10</b>
<b>3.4. VSWR AND TOTAL EFFICIENCY</b>	<b>11</b>
<b>3.5. RADIATION PATTERNS (1561, 1575, and 1598-1606 MHz), GAIN AND EFFICIENCY</b>	<b>12</b>

# 1. PRODUCT DESCRIPTION NN02-224

The RUN mXTEND<sup>™</sup> antenna booster has been specifically designed for providing multiband performance in wireless devices enabling worldwide coverage. It is a multipurpose antenna solution capable of being adapted, with a high level of flexibility, to the antenna designer needs. The same antenna part can be used to cover different frequency ranges, since it offers the antenna designer the flexibility of selecting the frequency regions to operate through just the customization of the matching network. In particular, this application note illustrates how to use it for operating the global navigation systems: GPS, GLONASS and BeiDou.

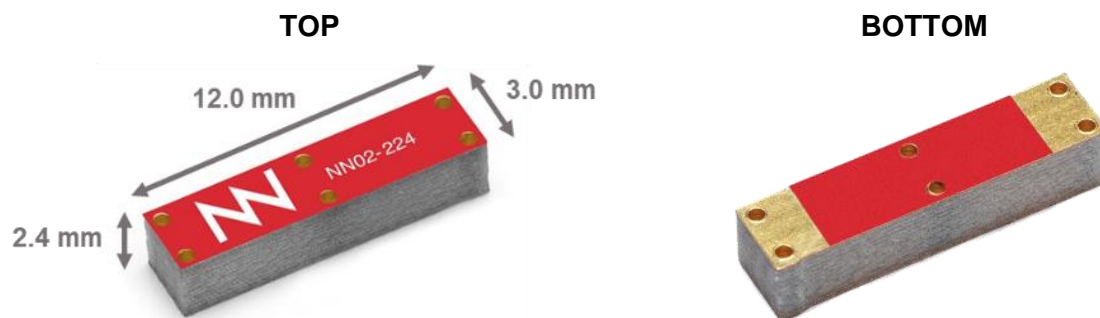

**Material:** The RUN mXTEND<sup>™</sup> antenna booster is built on glass epoxy substrate.

## APPLICATIONS

- GPS/GLONASS/BeiDou modules
- Navigators
- Track systems
- Handsets and Smartphones
- Tablets
- Digital Cameras
- Smart Watches

## BENEFITS

- High efficiency
- Small size
- Cost-effective
- Easy-to-use (pick and place)
- Off-the-Shelf Standard Product (no customization is required)

The RUN mXTEND<sup>™</sup> antenna booster belongs to a new generation of antenna solutions based on the Virtual Antenna<sup>™</sup> technology owned by Ignion. The technology is mainly focused on replacing conventional antenna solutions by miniature and standard components.

## 2. EVALUATION BOARD GPS/GLONASS/BeiDou

### 2.1. QUICK REFERENCE GUIDE

Technical features	1561 MHz	1575 MHz	1598 – 1606 MHz
Average Efficiency	> 75 %		> 80 %
Peak Gain	2.9 dBi	3.0 dBi	3.3 dBi
VSWR	< 1.5:1		
Radiation Pattern	Omnidirectional		
Polarization	Linear		
Weight (approx.)	0.19 g		
Temperature	-40 to +125 °C		
Impedance	50 Ω		
Dimensions (L x W x H)	12.0 mm x 3.0 mm x 2.4 mm		

Table 1 – Technical Features. Measures from the Evaluation Board. See Figure 1.

### 2.2. EVALUATION BOARD

This Evaluation Board EB\_NN02-224-1561-1606 integrates a UFL cable to connect the RUN mXTEND™ antenna booster with the SMA connector. The RUN mXTEND™ provides operation in three frequency regions, 1561MHz (BeiDou E1 band), 1575 MHz (GPS L1 band) and from 1598 MHz to 1606 MHz (GLONASS L1 band), through a single input/output port.

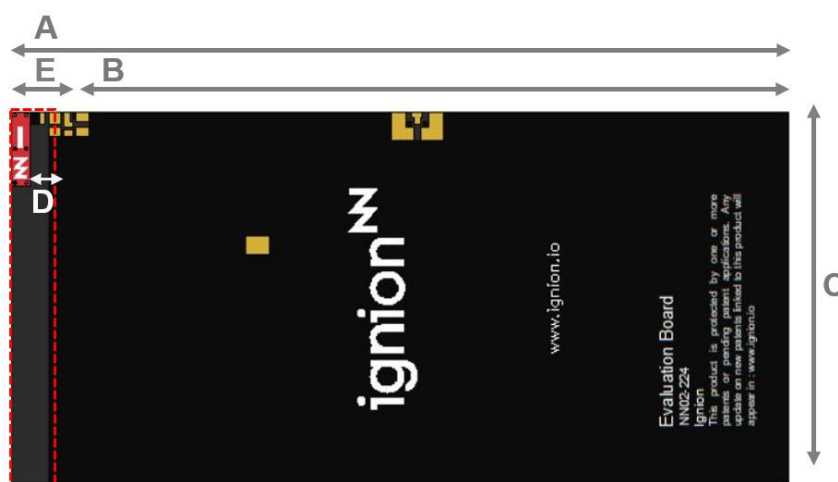

Measure	mm
A	126.5
B	120
C	60
D	2.5
E	6.5

**Tolerance:** ±0.2 mm

**D:** Distance between the RUN mXTEND™ antenna booster and the ground plane.

**Material:** The evaluation board is built on FR4 substrate. Thickness is 1 mm.

**Clearance Area:** 6.5 mm x 60 mm (E x C)

Figure 1 – EB\_NN02-224-1561-1606. Evaluation Board providing operation at BeiDou E1 band (1561 MHz), GPS L1 band (1575 MHz) and for GLONASS L1 band (from 1598 MHz to 1606 MHz).

This product and its use are protected by at least one or more of the following [patents](#) PAT. US 9,130,259 B2; PAT. US 8,237,615 B2. Other domestic and international patents pending. Additional information about patents related to this product is available at [www.ignion.io/virtual-antenna/](http://www.ignion.io/virtual-antenna/).

### 2.3. MATCHING NETWORK

The specs of a Ignion standard product are measured in their evaluation board, which is an ideal case. In a real design, components nearby the antenna, LCD's, batteries, covers, connectors, etc. affect the antenna performance. This is the reason why it is highly recommended placing pads compatible with 0402 and 0603 SMD components for a matching network as close as possible to the feeding point. Do it in the ground plane area, not in the clearance area. This provides a degree of freedom to tune the RUN mXTEND™ antenna booster once the design is finished and taking into account all elements of the series (batteries, displays, covers, etc.).

Please notice that different devices with different ground planes and different components nearby the RUN mXTEND™ antenna booster may need a different matching network. To ensure optimal results, the use of high Q and tight tolerance components is highly recommended (Murata components). Please, if you need assistance contact [support@ignion.io](mailto:support@ignion.io) for more information related to the antenna booster matching service.

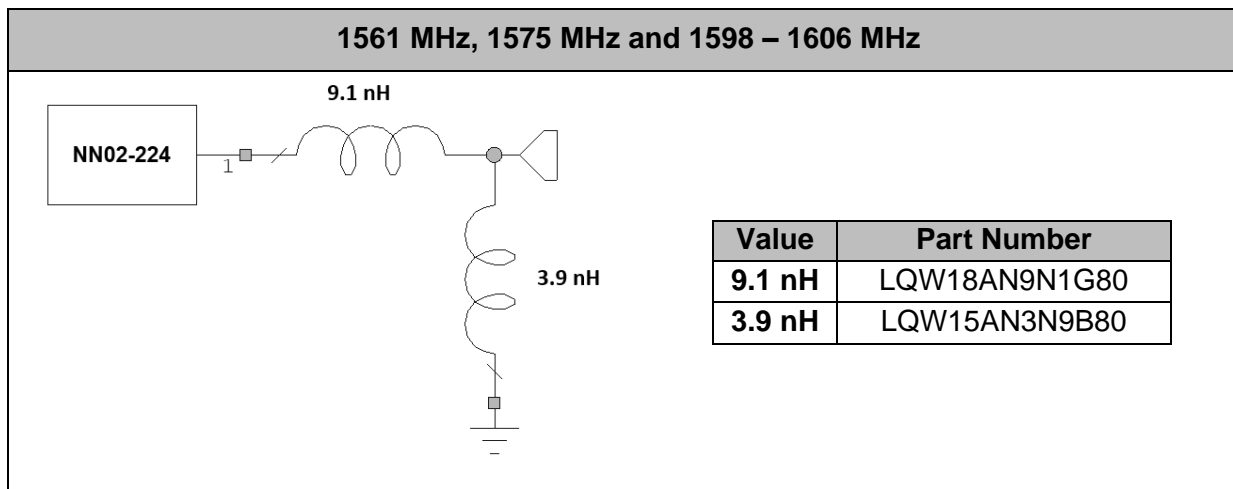

Figure 2 – Matching Network implemented in the evaluation board (Figure 1).

For additional information, please visit [www.ignion.io](http://www.ignion.io) or contact [info@ignion.io](mailto:info@ignion.io).

If you need assistance to design your matching network, please contact [support@ignion.io](mailto:support@ignion.io), or try our free-of-charge<sup>1</sup> **NN Wireless Fast-Track** design service, you will get your chip antenna design including a custom matching network for your device in 24h<sup>1</sup>. Other related to NN's range of R&D services is available at: <https://www.ignion.io/rdservices/>

<sup>1</sup> See terms and conditions for a free NN Wireless Fast-Track service in 24h at: <https://www.ignion.io/fast-track-project/>

## 2.4. VSWR AND TOTAL EFFICIENCY

VSWR (Voltage Standing Wave Ratio) and Total Efficiency versus Frequency (GHz).

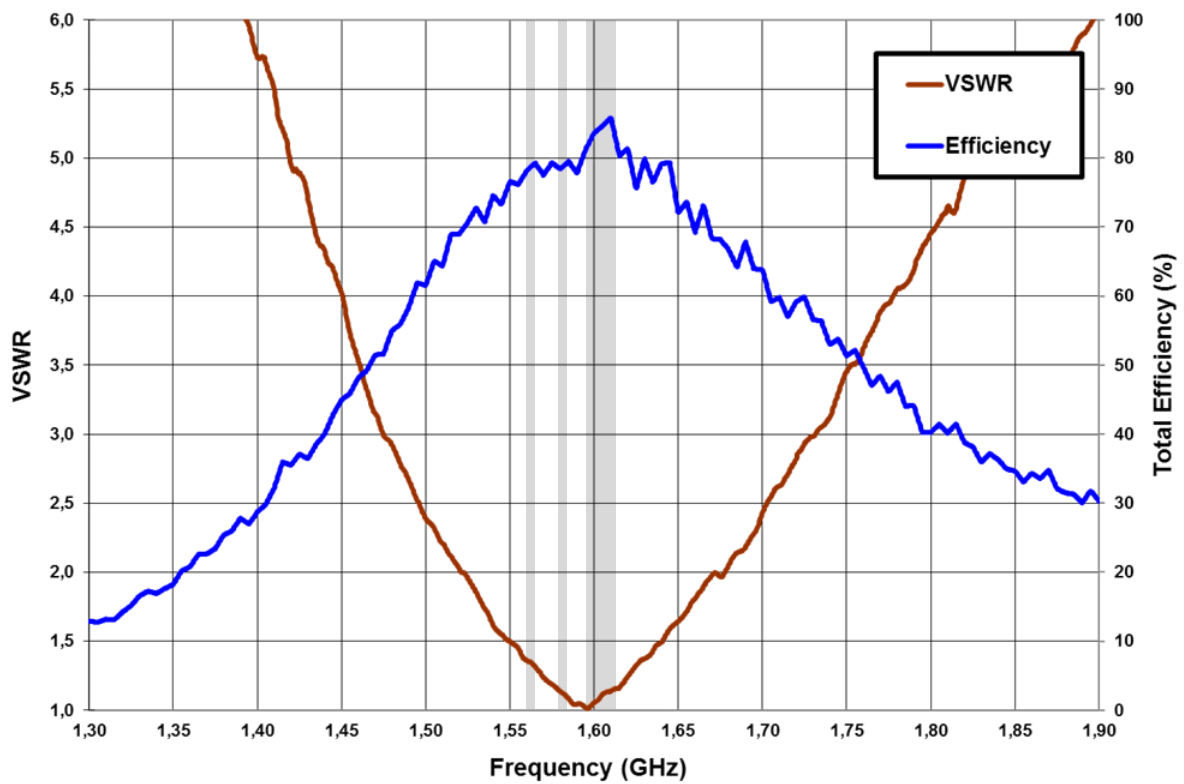

**Figure 3** – VSWR and Total Efficiency for BeiDou E1 band (1561 MHz), GPS L1 band (1575 MHz) and GLONASS L1 band (1598 – 1606 MHz) (from the evaluation board (Figure 1)).

## 2.5. RADIATION PATTERNS (1561, 1575 and 1598-1606 MHz), GAIN AND EFFICIENCY

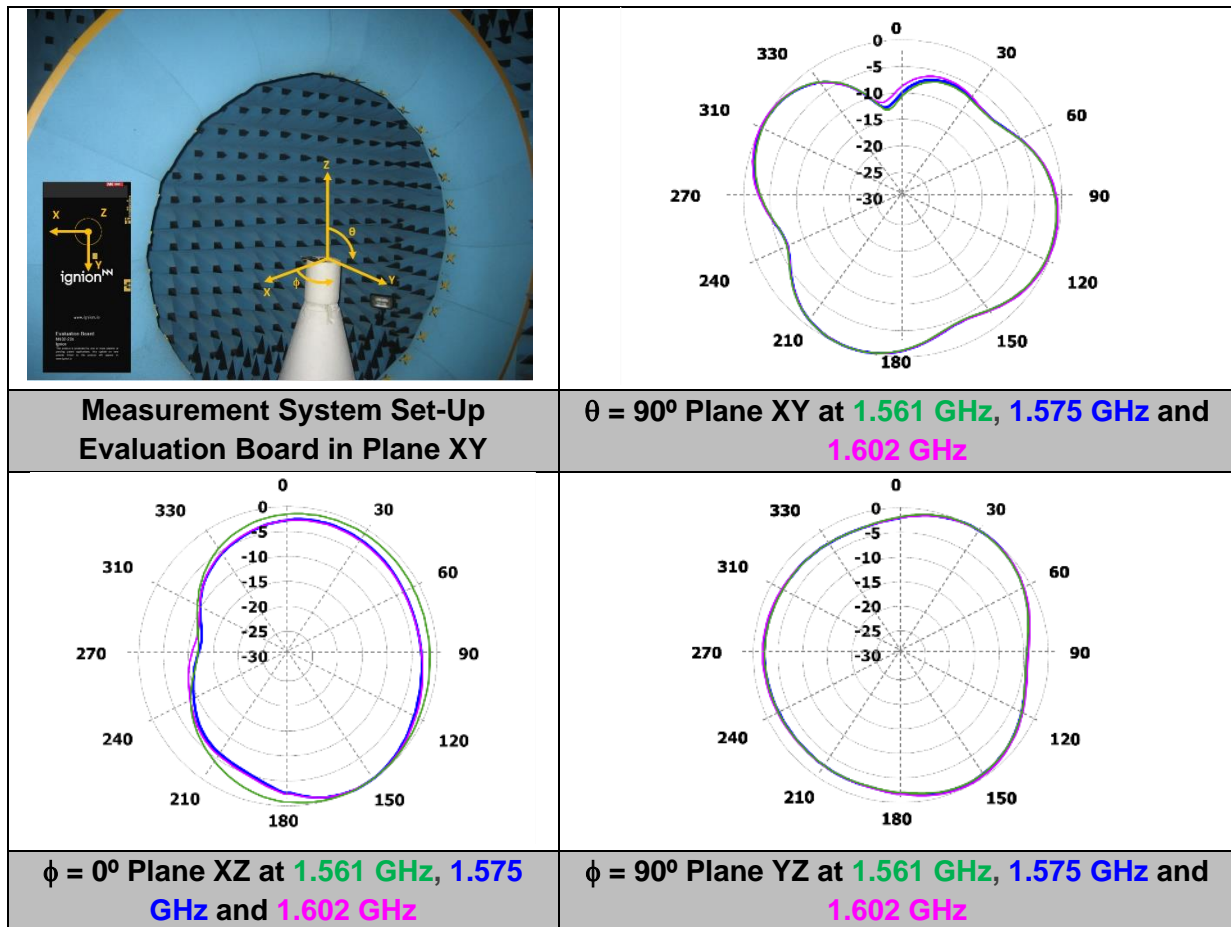

<b>BeiDou</b>	<b>Gain</b>	2.9 dBi	
	<b>Efficiency</b>	78.4%	
<b>GPS</b>	<b>Gain</b>	3.0 dBi	
	<b>Efficiency</b>	79.3 %	
<b>GLONASS</b>	<b>Gain</b>	<b>Peak Gain</b>	3.3 dBi
		<b>Average Gain across the band</b>	3.2 dBi
		<b>Gain Range across the band (min, max)</b>	3.1 $\leftrightarrow$ 3.3 dBi
	<b>Efficiency</b>	<b>Peak Efficiency</b>	84.9 %
		<b>Average Efficiency across the band</b>	83.8 %
		<b>Efficiency Range across the band (min, max)</b>	82.7 – 84.9 %

**Table 2** – Antenna Gain and Total Efficiency from the evaluation board (Figure 1) for BeiDou E1 (1561 MHz), GPS L1 (1575 MHz) and GLONASS L1 (1598 – 1606 MHz) bands. Measures made in the Satimo STARGATE 32 anechoic chamber.



### 3. EVALUATION BOARD CR80 GPS/GLONASS/BeiDou

#### 3.1. QUICK REFERENCE GUIDE

Technical features	1561 MHz	1575 MHz	1598 – 1606 MHz
Average Efficiency	> 80 %		> 85 %
Peak Gain	3.1 dBi	3.3 dBi	3.6 dBi
VSWR	< 1.5:1		
Radiation Pattern	Omnidirectional		
Polarization	Linear		
Weight (approx.)	0.19 g		
Temperature	-40 to +125 °C		
Impedance	50 Ω		
Dimensions (L x W x H)	12.0 mm x 3.0 mm x 2.4 mm		

Table 3 – Technical Features. Measures from the Evaluation Board. See Figure 4.

#### 3.2. EVALUATION BOARD

This Evaluation Board EB\_NN02-224-CR80-1561-1606 integrates a UFL cable to connect the RUN mXTEND™ antenna booster with the SMA connector. The RUN mXTEND™ provides operation in three frequency regions, 1561 MHz (BeiDou E1 band), 1575 MHz (GPS L1 band) and from 1598 MHz to 1606 MHz (GLONASS L1 band), through a single input/output port.

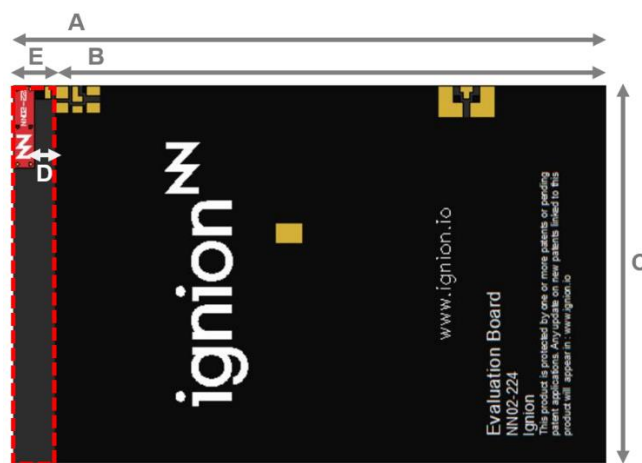

Measure	mm
A	86
B	79.5
C	54
D	2.5
E	6.5

Tolerance: ±0.2 mm

D: Distance between the RUN mXTEND™ antenna booster and the ground plane.

Material: The evaluation board is built on FR4 substrate. Thickness is 1 mm.

Clearance Area: 6.5 mm x 54 mm (E x C)

Figure 4 – EB\_NN02-224-CR80-1561-1606 in CR80 standard format. Evaluation Board providing operation for BeiDou E1 band (1561 MHz), GPS L1 band (1575 MHz) and for GLONASS L1 band (from 1598 MHz to 1606 MHz).

This product and its use are protected by at least one or more of the following [patents](#) PAT. US 9,130,259 B2; PAT. US 8,237,615 B2. Other domestic and international patents pending. Additional information about patents related to this product is available at [www.ignion.io/virtual-antenna/](http://www.ignion.io/virtual-antenna/).

### 3.3. MATCHING NETWORK

The specs of a Ignion standard product are measured in their evaluation board, which is an ideal case. In a real design, components nearby the antenna, LCD's, batteries, covers, connectors, etc. affect the antenna performance. This is the reason why it is highly recommended placing pads compatible with 0402 and 0603 SMD components for a matching network as close as possible to the feeding point. Do it in the ground plane area, not in the clearance area. This provides a degree of freedom to tune the RUN mXTEND™ antenna booster once the design is finished and taking into account all elements of the series (batteries, displays, covers, etc.).

Please notice that different devices with different ground planes and different components nearby the RUN mXTEND™ antenna booster may need a different matching network. To ensure optimal results, the use of high Q and tight tolerance components is highly recommended (Murata components). Please, if you need assistance contact [support@ignion.io](mailto:support@ignion.io) for more information related to the antenna booster matching service.

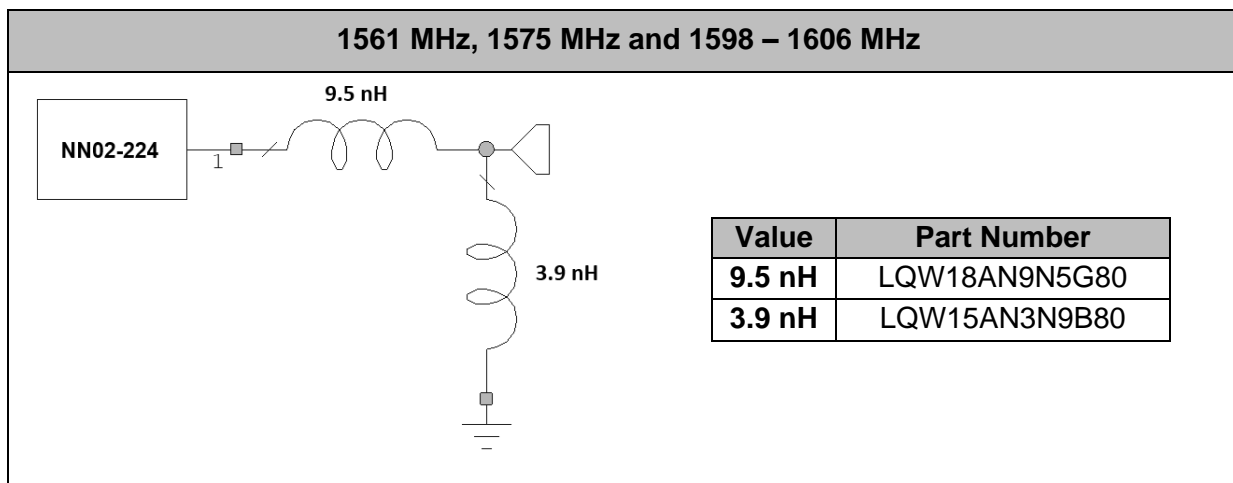

Figure 5 – Matching Network implemented in the evaluation board (Figure 4).

For additional information, please visit [www.ignion.io](http://www.ignion.io) or contact [info@ignion.io](mailto:info@ignion.io).

If you need assistance to design your matching network, please contact [support@ignion.io](mailto:support@ignion.io), or try our free-of-charge<sup>1</sup> **NN Wireless Fast-Track** design service, you will get your chip antenna design including a custom matching network for your device in 24h<sup>2</sup>. Other related to NN's range of R&D services is available at: <https://www.ignion.io/rdservices/>

<sup>2</sup> See terms and conditions for a free NN Wireless Fast-Track service in 24h at: <https://www.ignion.io/fast-track-project/>

### 3.4. VSWR AND TOTAL EFFICIENCY

VSWR (Voltage Standing Wave Ratio) and Total Efficiency versus Frequency (GHz).

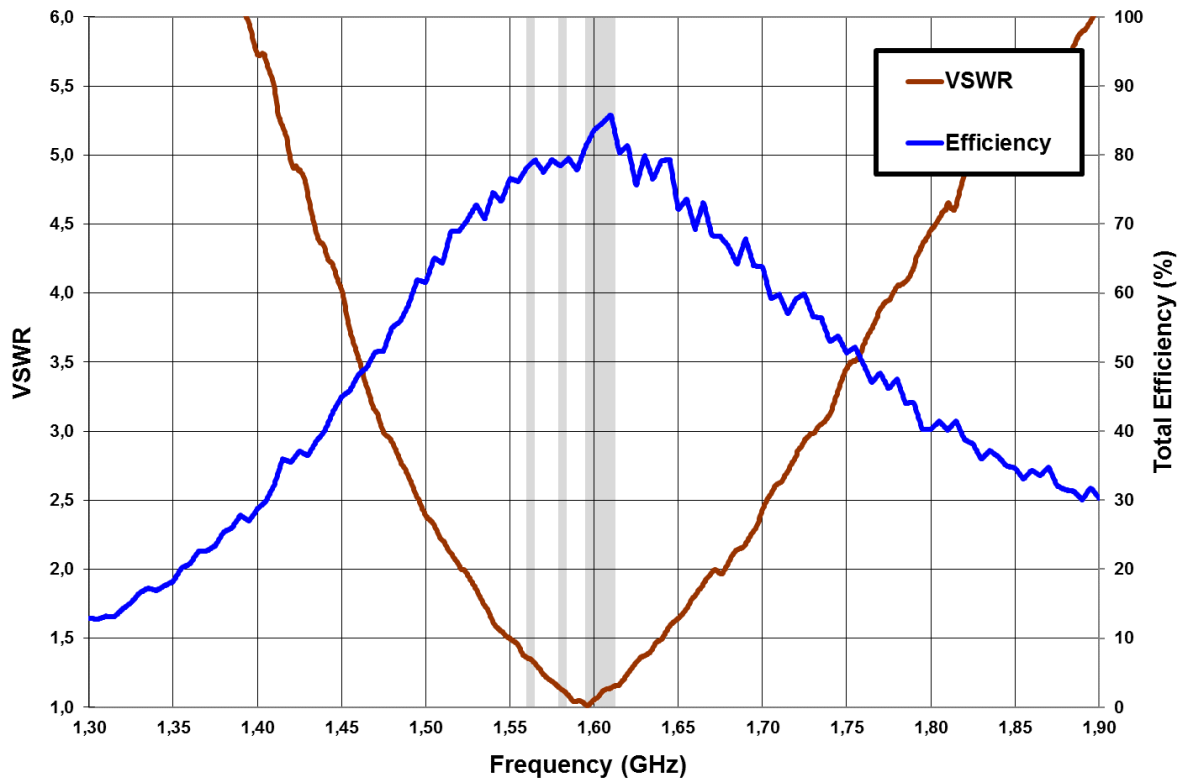

**Figure 6** – VSWR and Total Efficiency for BeiDou E1 (1561 MHz), GPS L1 band (1575 MHz) and GLONASS L1 band (1598 – 1606 MHz) (from the evaluation board (Figure 4)).

### 3.5. RADIATION PATTERNS (1561, 1575, and 1598-1606 MHz), GAIN AND EFFICIENCY

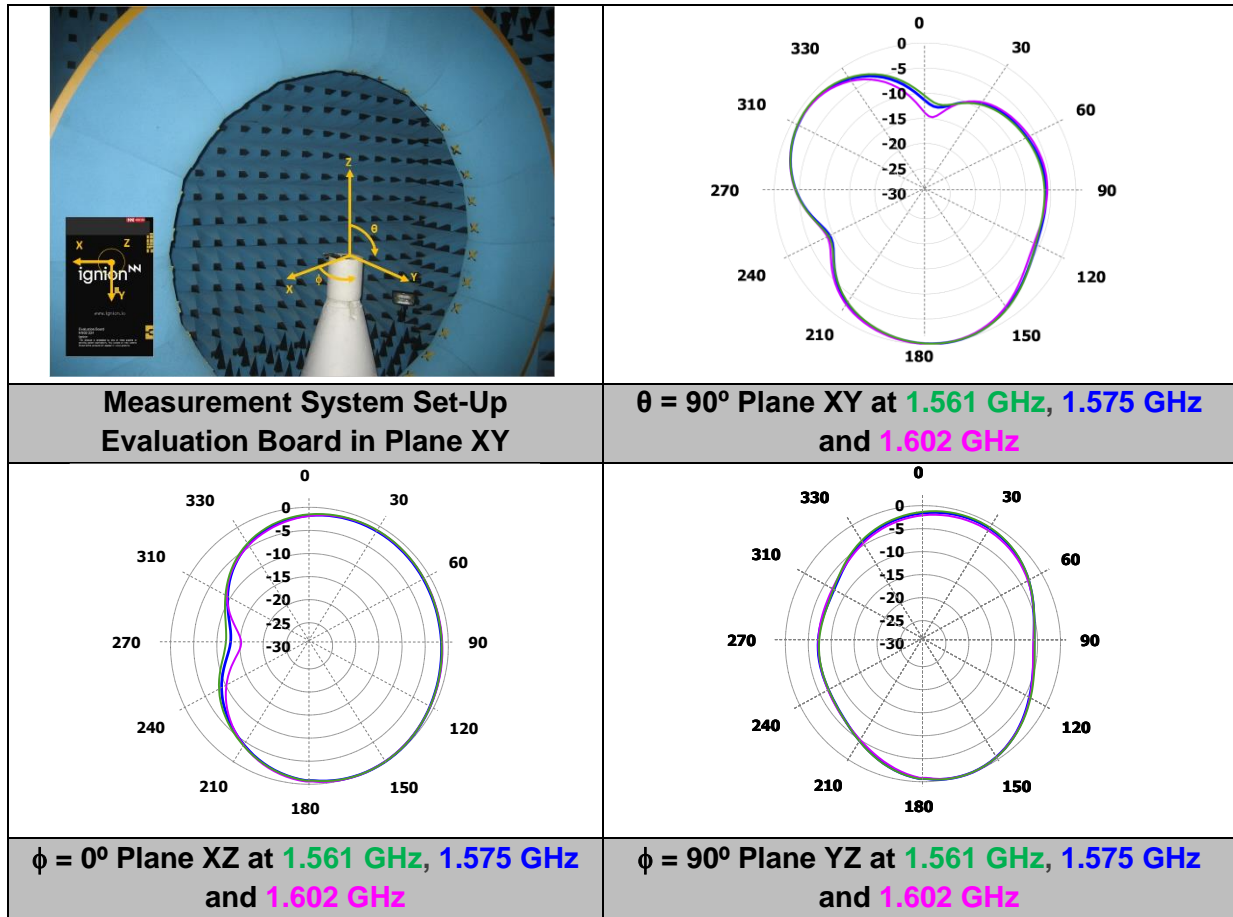

<b>BeiDou</b>		<b>Gain</b>	3.1 dBi
		<b>Efficiency</b>	84.7 %
<b>GPS</b>		<b>Gain</b>	3.3 dBi
		<b>Efficiency</b>	84.9 %
<b>GLONASS</b>	<b>Gain</b>	<b>Peak Gain</b>	3.6 dBi
		<b>Average Gain across the band</b>	3.5 dBi
		<b>Gain Range across the band (min, max)</b>	3.4 ↔ 3.6 dBi
	<b>Efficiency</b>	<b>Peak Efficiency</b>	88.7 %
		<b>Average Efficiency across the band</b>	87.6 %
		<b>Efficiency Range across the band (min, max)</b>	86.4 – 88.7 %

**Table 4** – Antenna Gain and Total Efficiency from the evaluation board (Figure 4) for BeiDou E1 (1561 MHz), GPS L1 (1575 MHz) and GLONASS L1 (1598 – 1606 MHz) bands. Measures made in the Satimo STARGATE 32 anechoic chamber.

ignion<sup>™</sup>

Your innovation.  
Accelerated.

Contact:  
[support@ignion.io](mailto:support@ignion.io)  
+34 935 660 710

#### Barcelona

Av. Alcalde Barnils, 64-68 Modul C, 3a pl.  
Sant Cugat del Vallés  
08174 Barcelona  
Spain

#### Shanghai

Shanghai Bund Centre  
18/F Bund Centre, 222 Yan'an Road East,  
Huangpu District  
Shanghai, 200002  
China

#### New Dehli

New Delhi, Red Fort Capital Parsvnath Towers  
Bhai Veer Singh Marg, Gole Market,  
New Delhi, 110001  
India

#### Tampa

8875 Hidden River Parkway  
Suite 300  
Tampa, FL 33637  
USA