

ignion[™]

Your innovation.
Accelerated.

RUN mXTEND[™] – THE ANTENNA FOR IOT: NB-IOT, LORA, ZIGBEE OR SIGFOX

APPLICATION NOTE
RUN mXTEND[™] (NN02-224)

TABLE OF CONTENTS

1. PRODUCT DESCRIPTION NN02-224	4
2. ONE ANTENNA, MANY DEVICES	5
2.1. PERFORMANCE IN DIFFERENT PCB SIZES	5
2.2. VSWR AND EFFICIENCY	6
2.3. MATCHING NETWORK	7

1. PRODUCT DESCRIPTION NN02-224

The market for the Internet of Things continues grow and the expanding diversity of IoT devices means product configurations are endless. For this application note we have tested the RUN mXTEND[™] chip antenna component's (NN02-224) performance when mounted onto various sized ground planes. We show the impact of ground plane size on performance in order to provide the most relevant results for those who design IoT devices of various dimensions. Additionally, we illustrate how to use the RUN mXTEND[™] chip antenna component for operating at the ISM bands, which are frequently used in IoT devices.

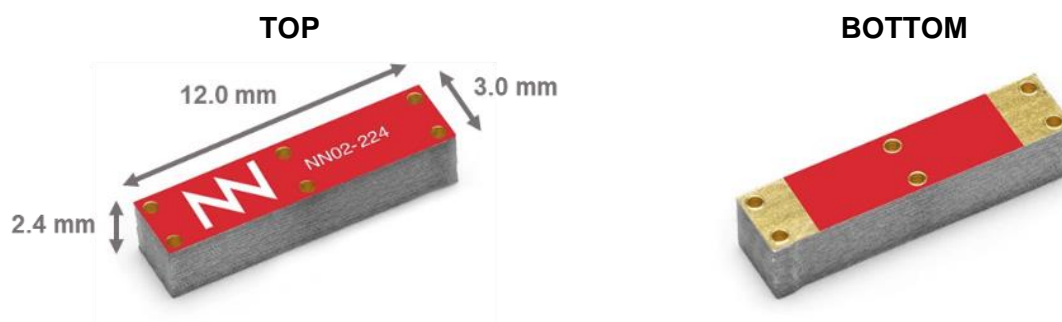

Material: The RUN mXTEND[™] antenna booster is built on glass epoxy substrate.

APPLICATIONS

- Smart Metering
- Smart City & Smart Building
- Industrial IoT
- Remote monitoring and control
- Sensors
- Personal & Asset Tracking
- Fleet management
- RFID
- Retail
- Security Systems
- Smart Home
- Medical

BENEFITS

- High efficiency
- Small size
- Cost-effective
- Easy-to-use (pick and place)
- Multiband behaviour (worldwide standards)
- Off-the-Shelf Standard Product (no customization is required)

The RUN mXTEND[™] antenna booster (NN02-224) provides multiband performance in wireless devices throughout a large range of frequencies (698-960 MHz, 1710-2690 MHz and 3400-3800 MHz), enabling worldwide coverage and allowing operation in **multiple IoT related communication standards** such as **NB-IoT, LoRa, Zigbee, SigFox, Neul, Thread, Z-Wave, Weightless**, all **mobile GSM/UMTS/LTE** bands for **2G, 3G, 4G, 5G, Bluetooth** and **WIFI**. Based on Ignion' proprietary Virtual Antenna[™] technology, the RUN mXTEND[™] belongs to a new generation of antenna products focused on replacing conventional antenna solutions with miniature, off-the-shelf components that drive fast, intelligent design. This breakthrough technology has been specifically designed to fit a diverse set of wireless applications – IoT devices are just one of the many environments where this tiny antenna can be transformational.

2. ONE ANTENNA, MANY DEVICES

2.1. PERFORMANCE IN DIFFERENT PCB SIZES

For demonstration purposes, the performance of the RUN mXTEND[™] chip antenna component is measured in different PCB boards within the 863-928 MHz frequency range as used in IoT standards such as NB-IoT, LoRa, Zigbee and SigFox. Please notice that the RUN mXTEND[™] is able to cover a much wider range of frequencies and standards; if your IoT device is to operate in any other band within the 698MHz to 3800MHz range you are welcome to contact support@ignion.io for assistance.

Each PCB board in the following set-up integrates a UFL cable to connect the RUN mXTEND[™] antenna booster with a SMA connector so that VSWR and antenna efficiency can be tested. The following results cover a wide scope of ground plane sizes (length and width), ranging from 75mm x 54mm down to 40mm x 20mm.

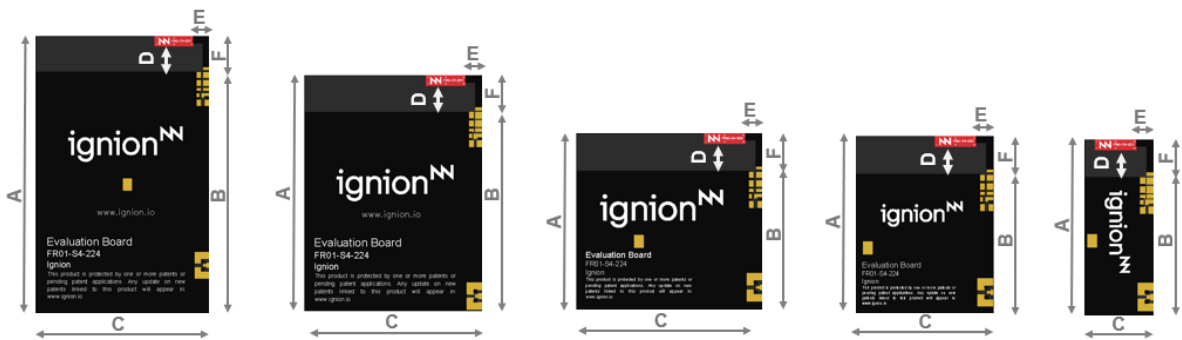

Figure 1 – Evaluation boards with different ground plane dimensions that provide operation from 863 MHz to 928 MHz.

Measure	mm
A	86 - 51
B	75 - 40
C	54 - 20
D	8.0
E	5.0
F	11.0

D: Distance between the RUN mXTEND[™] antenna booster and the ground plane.

Material: The Evaluation Board is built on FR4 substrate. Thickness is 1 mm.

Clearance Area: C x F mm

Tolerance: ±0.2 mm

2.2. VSWR AND EFFICIENCY

VSWR (Voltage Standing Wave Ratio) and Total Efficiency versus Frequency (GHz).

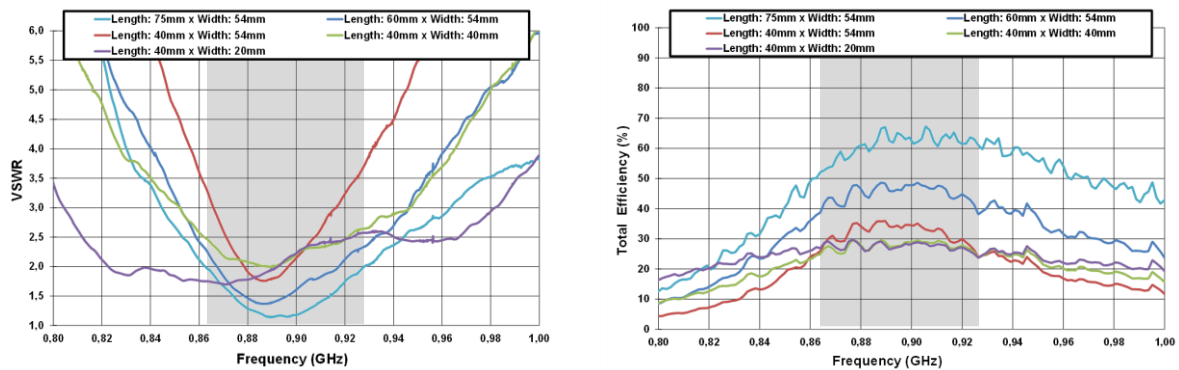

Figure 2 – VSWR and Total Efficiency for the 863 – 928 MHz frequency range (Figure 1).

Dimensions (B x C)	LFR (863 – 928MHz)				
	η_a 863MHz	η_a 928MHz	Min	Max	Av. η_a
75 mm x 54 mm	50.8	59.7	50.8	67.3	61.2
60 mm x 54 mm	38.1	39.1	38.1	48.6	45.0
40 mm x 54 mm	25.3	24.4	23.9	35.9	31.7
40 mm x 40 mm	24.6	24.3	23.7	29.5	27.5
40 mm x 20 mm	27.1	24.5	23.7	29.7	27.4

Table 1 – Total efficiency (%) comparison considering the different dimensions.

2.3. MATCHING NETWORK

The matching network design and value components for each device and PCB size is provided here. While the antenna component and matching network design and topology remains the same, the value of the components will be adapted to every PCB size for an optimum performance. The specs of a Ignion standard product are measured in a reference evaluation board, to isolate the antenna performance from other system elements. However, when incorporating into real designs, nearby components such as LCD's, batteries, covers and connectors may affect the antenna performance. For this reason, placing pads compatible with 0402 and 0603 SMD components for a matching network as close as possible to the feeding point is highly recommended. The matching network should be implemented in the ground plane area rather than the clearance area, this will provide a degree of freedom for tuning the RUN mXTEND™ antenna component once the design is finished, taking into account all elements of the system (batteries, displays, covers, etc.).

Please notice that different devices with different ground planes and different components nearby the RUN mXTEND™ antenna component may require a fine tuning of the matching networks. To ensure optimal results, the use of high Q and tight tolerance components is highly recommended (Murata components).

If you need assistance, please contact support@ignion.io for more information related to our chip antenna component matching service.

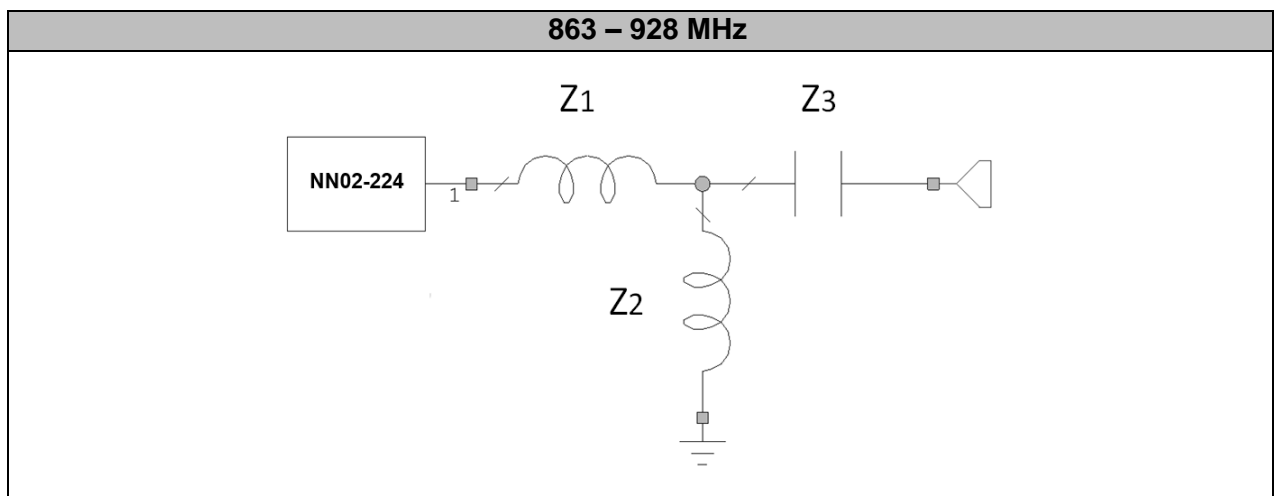

Figure 3 – Topology of matching network mounted for the different solutions.

Dimensions (B x C)	Z ₁	Z ₂	Z ₃
75 mm x 54 mm	24 nH	7.5 nH	1.8 pF
60 mm x 54 mm	25 nH	6.8 nH	1.8 pF
40 mm x 54 mm	25 nH	7.2 nH	1.5 pF
40 mm x 40 mm	27 nH	7.2 nH	2.1 pF
40 mm x 20 mm	27 nH	8.2 nH	2.0 pF

Table 2 – Values of the components for each different solution.

Value		Part Number
Z1	24 nH	LQW18AN24NG00
	25 nH	LQW18AN25NG80
	27 nH	LQW18AN27NG80
Z2	7.5 nH	LQW18AN7N5C80
	6.8 nH	LQW18AN6N8C10
	7.2 nH	LQW18AN7N2C80
	8.2 nH	LQW18AN8N2C80
Z3	1.8 pF	GJM1555C1H1R8WB01
	1.5 pF	GJM1555C1H1R5WB01
	2.1 pF	GJM1555C1H2R1WB01
	2.0 pF	GJM1555C1H2R0WB0

Table 3 – Values and part numbers of the components used for the matching networks for the cases with dimensions 75mm x 54mm, 60mm x 54mm, 40mm x 54mm, 40mm x 40mm, 40mm x 20mm.

For additional information, please visit www.ignion.io or contact info@ignion.io.

If you need assistance to design your matching network, please contact support@ignion.io, or try our free-of-charge¹ **NN Wireless Fast-Track** design service, you will get your chip antenna design including a custom matching network for your device in 24h¹. Other related to NN's range of R&D services is available at: <https://www.ignion.io/rdservices/>

¹ See terms and conditions for a free NN Wireless Fast-Track service in 24h at: <https://www.ignion.io/fast-track-project/>

Ignion products are protected by [Ignion patents](#).

All information contained within this document is property of Ignion and is subject to change without prior notice. Information is provided “as is” and without warranties. It is prohibited to copy or reproduce this information without prior approval.

Ignion is an ISO 9001:2015 certified company. All our antennas are lead-free and RoHS compliant.

ISO 9001: 2015 Certified



This project has received funding from the European Union’s Horizon 2020 research and innovation programme under grant agreement N° 674491



ignion[™]

Your innovation.
Accelerated.

Contact:
support@ignion.io
+34 935 660 710

Barcelona

Av. Alcalde Barnils, 64-68 Modul C, 3a pl.
Sant Cugat del Vallés
08174 Barcelona
Spain

Shanghai

Shanghai Bund Centre
18/F Bund Centre, 222 Yan'an Road East,
Huangpu District
Shanghai, 200002
China

New Dehli

New Delhi, Red Fort Capital Parsvnath Towers
Bhai Veer Singh Marg, Gole Market,
New Delhi, 110001
India

Tampa

8875 Hidden River Parkway
Suite 300
Tampa, FL 33637
USA